

Mahindra **FURIO 11 6kl Diesel Bowser**

**THE BEST TRUCK FOR  
FUELLING UP THE ECONOMY**

Now with **TANKUP** Fuel Bowser body fitment  
FUELLING YOUR GROWTH



MAHINDRA, INDIA'S  
MOST FUEL-EFFICIENT  
TRUCK RANGE.  
GUARANTEED.

**FUELSMART**  
For higher mileage

**IMAXX**  
For transporting efficiency

Approved by  
**PESO**\*\*

NEW MAHINDRA  
**FURIO**  
MORE PROFIT GUARANTEED\*

\*For details of this guarantee, please refer to [www.mahindratruckandbus.com](http://www.mahindratruckandbus.com)

Note: \*\*Chassis is approved for POL application in accordance with Rule 70 (i)(ii)&(iii) of The Petroleum Rules, 2002  
\*Not part of OEM fitment

## ***NOW BUYING ANY OTHER TRUCK IS A BIG RISK.***

The brand new Mahindra **FURIO** comes with a never-before, industry-first package of 5 promises. Designed around your business needs, these promises assure you the Highest Earnings, Complete Peace of Mind, Best-in-Class Comfort, Safety and Risk-free Ownership Experience. In fact, this truck will transform your business in such a big way that buying any other truck would be a big risk.



**HIGHER PAYLOAD-  
HIGHER PROFIT GUARANTEED**



**BEST-IN-CLASS MILEAGE WITH  
FUELSMART TECHNOLOGY-  
HIGHER PROFIT GUARANTEED**



**BEST-IN-CLASS CABIN-  
BETTER COMFORT, SAFETY AND  
CONVENIENCE GUARANTEED**



**5 YEARS / 5 Lakh km  
TRANSFERABLE WARRANTY-  
PEACE OF MIND GUARANTEED**



**5 YEARS UNLIMITED km AMC FREE\*-  
FREE MAINTENANCE GUARANTEED**

# **MAHINDRA FURIO BS6 – A BIG LEAP FOR INDIAN TRANSPORT.**

This truck has everything it needs to transform the entire transport industry in India. Styled at the famous Italian automobile design and engineering company, Pininfarina, the Mahindra FURIO is crafted with striking looks and gives the assurance of outstanding performance. This proud addition to our truck range marks a new dawn for the Intermediate Commercial Vehicle (ICV) category and makes Mahindra a full range commercial vehicle player.



**WHEN YOU DELIVER HIGHER PROFITS, PEACE OF MIND AND PROSPERITY,  
THE WORLD ACKNOWLEDGES IT! NOT ONCE, NOT TWICE, BUT 3 TIMES!**

**CV of The Year: Mahindra FURIO**

◆ ICV Cargo Carrier of The Year: Mahindra FURIO 14

◆ Special Application CV of The Year: Mahindra FURIO 12 Reefer



# IT'S GOT EVERYTHING THE PERFECT DIESEL BOWSER NEEDS.

The Mahindra **FURIO** makes the perfect diesel bowser with its build, performance, driving comfort and safety. While its build makes it more profitable, it has several features that add to productivity.

## BUILT FOR BIG PROFITS.



**More Load Carrying Capacity:**  
Brings you more earnings



**Assured Higher Mileage with FuelSmart Technology:**  
Increases your profitability



**iMAXX Intelligent Telematics Technology:**  
Keeps track of your truck from anywhere and, makes transporting more efficient and profitable



**Superior Driving and Cabin Comfort:**  
Makes drivers more productive



### • TANKUP MOBILE DIESEL BOWSERS FEATURES:

- In compliance with the safety features as per Standard PESO Norms
- Tank with Box
- Pump
- Dispenser unit comes with digital reading and printer facility
- Hose reel is with spring facility, to facilitate ease of operation for the fuel operator
- Auto cut-off nozzle
- Re-usable filter / Strainer
- Pneumatic switch inside driver cabin to activate the PTO (Power Take Off#)

### • SPECIAL FEATURES:

- The bowser manhole cover and the dispensing valve can be controlled remotely, i.e. its opening and closing can be triggered through Tank Up app only.
- Tank Lock prevents any form of theft of fuel from the possible human touchpoints.



Mahindra **FURIO 11 6kl Diesel Bowser**

## **THE BEST TRUCK FOR FUELLING UP THE ECONOMY**

### **BUILT FOR PERFORMANCE**



**Strong and Rugged Aggregates:**  
Gives you greater vehicle reliability



**Lower Turning Circle Diameter:**  
For effortless city driving Conditions



**Standard front Anti-Roll Bar for  
Better Vehicle Stability**



#### **FURIO 11 Chassis**

5334 mm Straight Ladder and High Strength Low Alloy 550 Material Chassis with Reinforcements

7.9T @ 5334 mm

## MODEL TECHNICAL SPECIFICATIONS & FEATURES - FUEL BOWSER

Model	Mahindra FURIO 11 - 5334 mm CBC
GVW	11280 kg
Tyres	Tubeless Tyre 235/75 R17.5 Radial Tyre - 8.25 R 16
Engine	mDi Tech, 3.5 litre, 4 Cylinder, BS-VI (EGR + SCR Technology)
Max. Power	104 kW @ 2400 r/min
Max. Torque	525 Nm @ 1250 ~ 1800 (With Multimode)
Transmission	6 speed Overdrive Synchro Gearbox
Clutch Diameter	362 mm
Chassis Material & Section	HSLA 550, 210 x 65 x 5 mm Chassis with reinforcement
Fuel Tank	160 litre
Suspension	Front : Parabolic Springs Rear : Semi Elliptical Springs
Brakes	8 Bar System
Cabin	2.05 m Day Cab
Wheelbase	4000 mm
TCD (m)	14.9 m
Gradeability	34%

**MTBD Scope : CBC Supply\***

Features		FURIO	Comp. 1	Comp. 2
Engine	Hydraulic Lash Adjuster	√	x	x
	Auto Belt Tensioner	√	x	x
Safety	Cab - Energy Absorbing Mounts	√	x	x
	Wide Spread Fog Lamps	√	x	x
	Neutral Safety Start Switch	√	x	x
	Anti-Roll Bar	√	x	Option
	Wire Mesh @ Fuel Tank Neck	√	x	x
Comfort	SL Berth - Day Cab*	√	x	x
	Lounging Arrangement	√	x	x
	(Co Driver Side)			
	Air Outlets - Ventilation	8# Vents	4# Vents	4# Vents
	5 Deg. Cooler Cab	√	x	x
	(Lower Rake Angle Design)			
	Centre Seat cum Storage	√	x	x
	Day Cab			
	Sleeping Provision – Day Cab	√	x	x
	(Centre Seat)			
Convenience	Roof Luggage Carrier / Aero Kit	√	x	x
	Mounting Provision			

\*Mahindra Truck and Bus provides only a CBC variant perfect for construction of Fuel Bowser

\*Sleeper Berth is the optional fitment in FURIO 11

## **MAHINDRA FURIO 11 - 5334 mm CBC LAYOUT**

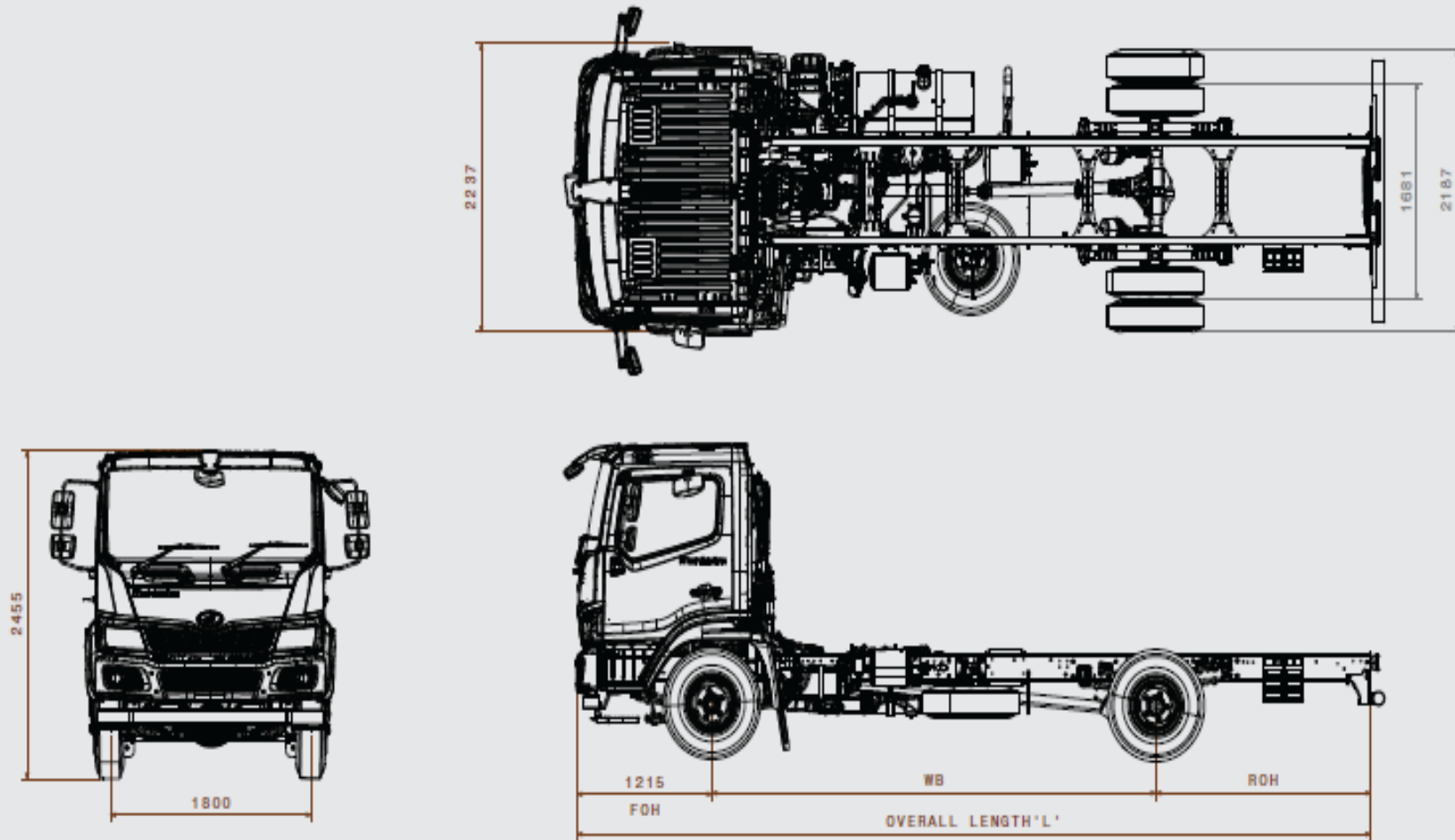

\*Refer Body Building, PTO, ABS, Protective Shield Guidelines, Dos & Don'ts

### **Note :**

- ARAI reports are available for Heat shield and Spark arrestor
- As per ARAI report , Spark arrestor is not required
- Vehicle should meet statutory licenses as per MV act and PESO act (if applicable).

## **MILEAGE, THE BIGGEST REASON FOR MAHINDRA FURIO'S PROFITABILITY.**

The Mahindra **FURIO** gives nothing less than the best mileage among ICVs in India. With fuel costs rising the way they are, this truck is the biggest game changer for your business.

- Best-in-class mileage
- Needs lower AdBlue, gives you more savings
- Smooth performance leads to extra trips and more earnings

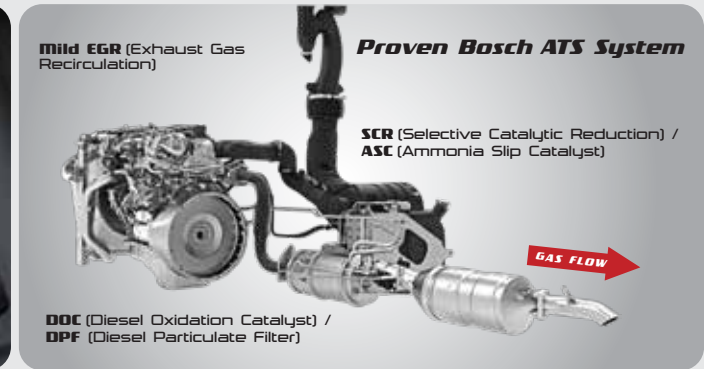

## **RELIABILITY THAT CONTRIBUTES TO GREATER EARNINGS.**

This truck has such a high degree of reliability that doing business smoothly becomes an absolute certainty. In other words, you can depend on the Mahindra **FURIO** to quietly deliver consistently high performance trip after trip. And its build quality makes breakdowns a long-faded dream.

- Rugged aggregates for unfailing reliability
- Consistent and reliable performance for on-time deliveries
- Allows drivers to clock more kilometres every month
- Minimal changes from BS4 to BS6 ensures similar high payload capacity

362 mm Diameter Organic Clutch



High Strength Low Alloy Material (HSLA 550)



Heavy-Duty Axle of Dana





# HAPPIER DRIVERS MAKE FOR MORE PRODUCTIVE DRIVERS.

The Mahindra **FURIO** makes driving more comfortable. This allows drivers to make more trips which in turn contributes significantly to your earnings. In fact the driver's comfort was an overlooked factor for many years. But Mahindra **FURIO** has changed that completely.

- Space enough for two drivers
- Roomy cabin, with lower noise and vibration
- Ample resting space in cabin during stopovers; means less tiredness over long drives
- Well-ventilated cabin brings down temperatures; especially in hot conditions
- Gives you market rate business edge by making on-time delivery possible
- Cabin provides higher operational comfort
- Comfort that makes night-driving less of an effort
- Good cabin ergonomics leading to higher trip efficiency



\*Sleeper Berth is the optional fitment in FURIO 11

## WITH MORE SAFETY COMES MORE ASSURANCE.

The Mahindra **FURIO** has several safety features to not only make drivers feel safer at higher average driving speeds but also give you the assurance of cargo safety. This is another reason why this truck is ideal for drivers and an important addition to your fleet, especially for perishable goods.



Widespread Fog Lamps for Excellent Visibility at Night and in Dark Conditions

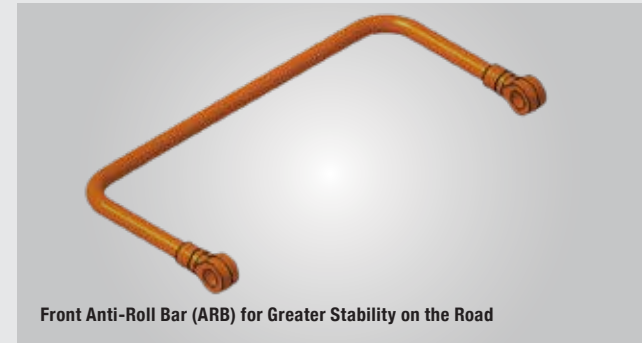

Front Anti-Roll Bar (ARB) for Greater Stability on the Road

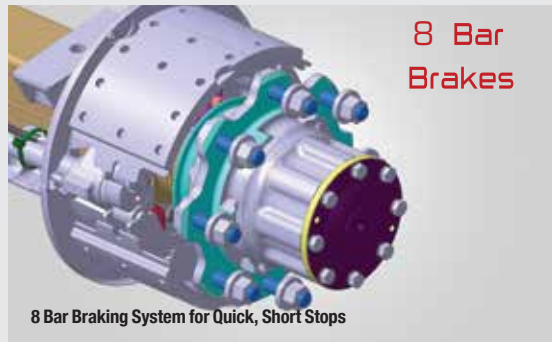

8 Bar Braking System for Quick, Short Stops



High Strength Low Alloy Chassis for Higher Strength and a Greater Sense of Security



Tubeless and Radial Tyres\* for High Speed Capacity, Better Stability And Puncture Resistance



Safest Cabin with Best-in-Class Survival Space



Think of the Mahindra iMAXX telematics technology as your personal assistant that updates you with vital information about your vehicles and business. Mahindra iMAXX comes with smart features like Accurate Refills, Live Tracking, Predictive Vehicle Health Monitoring, Fuel Efficiency Analysis, Theft Alerts, Fuel Consumption, Adblue Monitoring, Driver Behaviour Monitoring and a range of Automated Operation Reports. With the help of these features, owners can keep track of their vehicles and business 24/7.\*

## KEY FEATURES



### PERSONALISATION

As your business evolves, so does our technology to suit all your needs.



### ZERO DATA LOSS

It's equipped with a bigger battery and memory to store data. In addition, it also works on all generations - 4G, 3G and even 2G.



### 100% RELIABILITY

Mahindra iMAXX is backed by artificial intelligence so you get accurate results every day.



### SMART REPORTS

Gives analytical insights and reports regularly to monitor and grow your business.



### VEHICLE HEALTH MONITORING

- Provides fault codes and repair strategies
- Displays battery and alternator condition
- Engine temperature display
- Turbocharger and intercooler information



### FUEL AND ADBLUE ANALYSIS

- Fuel economy analysis
- Fuel filling and theft monitoring
- Adblue monitoring
- EV battery monitoring



### DRIVER BEHAVIOUR MONITORING

- Gear utilisation information
- Idling time monitoring
- Hard braking and harsh acceleration alerts
- Over-speeding alerts



### OPERATIONS AUTOMATION

- Hub report
- Vehicle utilisation report for enhancing overall efficiency
- Vehicle live data for course correction
- Location track and trace



Mahindra AASHRAY is an insurance policy for truck and bus drivers that comes free with every Mahindra truck and bus. It provides financial support up to Rs. 5 Lakh in case of loss of limb or life. It's our way of showing how deeply we care about the welfare of drivers. It's our way of making every Mahindra truck or bus even more complete.\*



Mahindra brings you MTRUST, the best way to buy and sell used Mahindra trucks and buses. We inspect each vehicle from bumper to bumper through 166 check points at our authorised dealerships under company trained mechanics and make them go through 36 tough health checks as well. If there are any worn-out/non-working parts, we refurbish them with genuine Mahindra spares to give you vehicles that are as good as new and outperform from the word go.\*



**Mahindra MCOVER makes you feel 3 times more secure.**

- ① Cashless and Zero Depreciation Settlement\*
- ② New vehicle replacement in case of total loss\*
- ③ Compensation for loss of income\*

## OUR GUARANTEES

GET **MORE PROFIT** OR GIVE THE TRUCK BACK.\*

GET THE **HIGHEST MILEAGE** OR GIVE THE TRUCK BACK.\*

GET BACK ON ROAD IN **48 HOURS** OR GET **₹1,000.00 PER DAY.\***

GET A **36-HOUR GUARANTEED TURNAROUND** AT OUR WORKSHOPS OR GET **₹3,000.00 PER DAY.\***



Mahindra brings you MTRUST, the best way to buy used Mahindra trucks. We put each vehicle through 166 tough health checks. Refurbish with only Mahindra spares. All to give you trucks that are as good as new and outperform right from the start. • UP TO 12 MONTHS WARRANTY • 1/2/3 STAR RATINGS • UP TO 3 FREE SERVICES • ROADSIDE ASSISTANCE • REFINANCE OPTIONS



Corporate: [contactmtb@mahindra.com](mailto:contactmtb@mahindra.com)  
Customer Care: [now24X7@mahindra.com](mailto:now24X7@mahindra.com)



[www.mahindratruckandbus.com](http://www.mahindratruckandbus.com)



Mahindra & Mahindra Ltd.,  
Truck and Bus Division, Marketing Division,  
2nd Floor, Mahindra Towers, Worli, Mumbai 400 018.

DEALER STAMP



visit [www.mahindratruckandbus.com](http://www.mahindratruckandbus.com)



MOBILE SERVICE VANS  
& WORKSHOPS



COUNTRY-WIDE SPARES  
& SERVICE NETWORK

Note: In view of our policy of continuously improving our products, we reserve the right to alter specifications or design without prior notice and without liability. Illustrations do not necessarily show the vehicle in its standard form. Accessories shown are not part of the standard equipment. Colour shades shown may vary. E. & O.E.

\*For details of this guarantee, please refer to the website [www.mahindratruckandbus.com](http://www.mahindratruckandbus.com)