

# ALL NEW MAHINDRA CRUZIO GRANDE. THE MOST COMFORTABLE AND PROFITABLE BUS IN ITS CLASS.



GET A 36-HOUR  
GUARANTEED TURNAROUND  
AT OUR WORKSHOP OR  
GET ₹3,000 PER DAY.\*



GET BACK ON THE ROAD  
IN 48 HOURS OR GET  
₹1,000 PER DAY.\*



mahindra  
**CRUZIO**  
GRANDE

**PRESENTING YOUR NEW BUSINESS PARTNER  
MAHINDRA CRUZIO GRANDE.  
COMFORTABLE RIDE. PROFITABLE BUSINESS.**

**MEET THE MOST LUXURIOUS BUS FROM MAHINDRA.**

**MILEAGE AND POWER AT THE TOUCH OF A SWITCH.**



Developed by Mahindra to give your business a competitive edge, the FuelSmart switches let you choose between superior mileage and optimum power as and when your business demands. Turn on the Heavy mode when your bus is full. And simply switch on the Light mode when running empty. Each mode squeezes the maximum efficiency from the mDi Tech FuelSmart engine.



FuelSmart Technology

**ENJOY ERGONOMICALLY DESIGNED COMFORT.**

Mahindra CRUZIO GRANDE is designed with thoughtful features that strike the perfect balance to ensure that both passengers and the driver are comfortable.

- Best-In-Class ride comfort with parabolic suspension
- Wide and Comfortable seats
- Smartly located sliding windows with better ventilation and illumination
- Low NVH (Noise-Vibration-Harshness)
- Stylish front and rear FRP fascia

**DRIVE THE LPO ADVANTAGE.**

LPO means 'Long Platform Overhang', which is a variant of the LP chassis. The overhang offers a long loading span without increasing the number of axles and tonnage. The LPO advantage in Mahindra CRUZIO GRANDE shifts more control into the hands of the driver offering better visibility and also ensures the safety of the passengers. The special feature of this bus is the door being ahead of the front wheel. This also creates an additional benefit by making optimum use of space for an extra passenger seat. It's time to add the LPO edge to your business, it's time to add Mahindra CRUZIO GRANDE to your fleet.



Best-In-Class Mileage



Designed Around Your Safety



Maximum Convenience



Most advanced Telematics Technology

## WHAT'S AT THE HEART OF MAHINDRA CRUZIO GRANDE?

This luxurious vehicle is powered by Mahindra's mDi Tech FuelSmart engine. The engine is powerful, super-efficient, low on friction, and comes with FuelSmart technology. But most importantly, it is backed by Mahindra's reputed CRDe expertise of more than a decade. This engine has an 1800 Bar Common Rail System and an Alternator Wastegate Turbocharger that together give you improved performance; by delivering a unique combination of higher power and higher fuel economy. A Hydraulic Lash Adjuster (HLA) means no more tappet setting every now and then. Same with the Auto Belt Tensioner which sets itself and requires no manual adjustments.



Proven mDi Tech Engine

## MAHINDRA BS6 AFTER TREATMENT SYSTEM LOWER ADBLUE MEANS HIGHER EARNINGS.

Mahindra CRUZIO GRANDE is not only built for profits but also for savings. Use Mahindra recommended AdBlue Maximile Plus for lower AdBlue Consumption that means fewer trips for refueling and lower AdBlue expenses. And what does this mean for your transport business? Increased earnings of course.

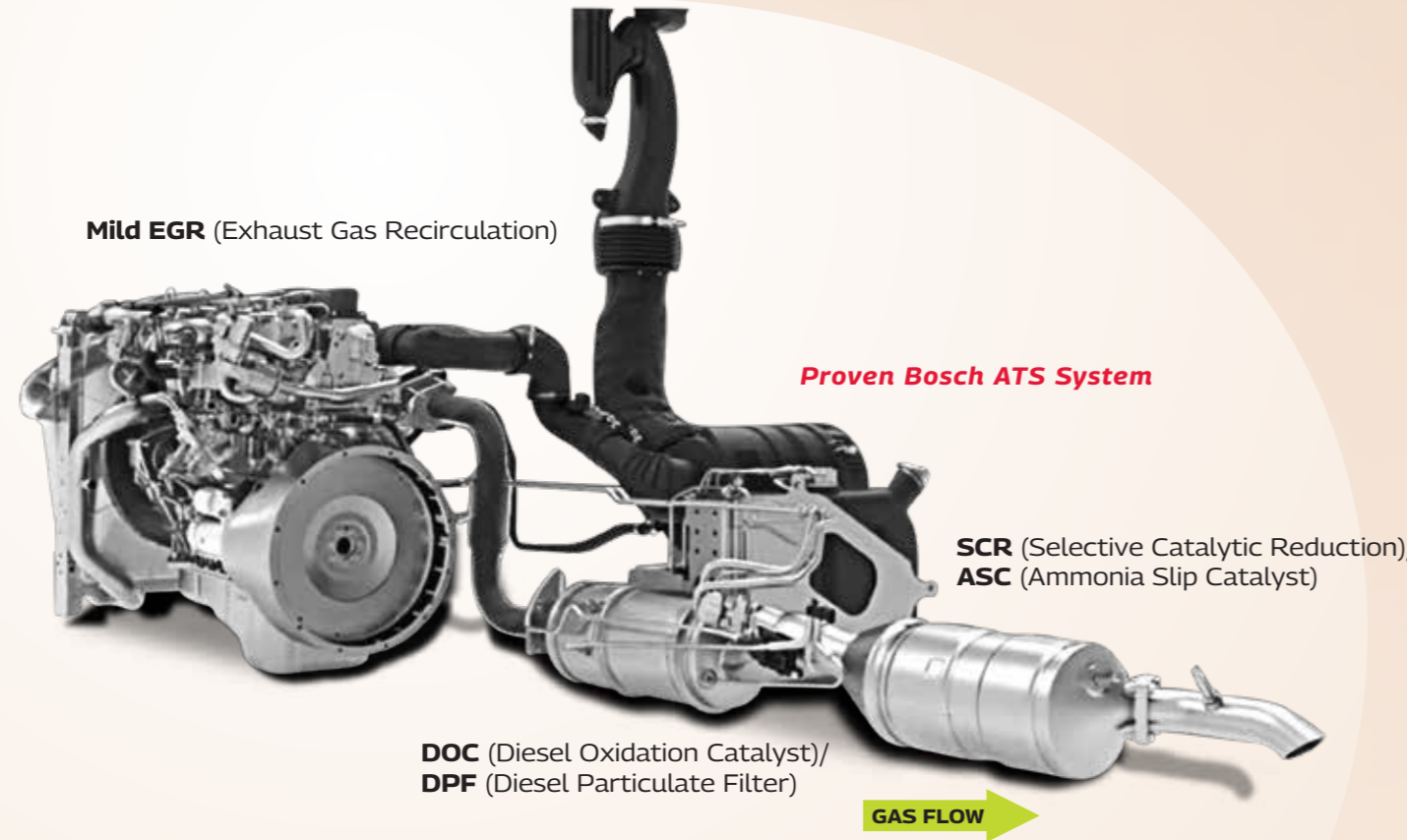

Mild EGR (Exhaust Gas Recirculation)

Proven Bosch ATS System

SCR (Selective Catalytic Reduction)/  
ASC (Ammonia Slip Catalyst)

DOC (Diesel Oxidation Catalyst)/  
DPF (Diesel Particulate Filter)

GAS FLOW

## DESIGNED TO MAKE EVERY RIDE TO OFFICE SMOOTH AND COMFORTABLE.



The Widest and Most Comfortable Seats to ensure shoulders don't rub. Wider Seats and Spacious Gangway



Ergonomically designed seat with best Lumbar Support.



Roomy and Well-Ventilated Saloon like a Living Room



Softer Parabolic Suspension with Rubber Tips for Best-In-Class Comfort to Absorb Bumps and Jerks

## THOUGHTFUL TOUCHES THAT KEEP THE DRIVER IN COMFORTABLE, ALWAYS.

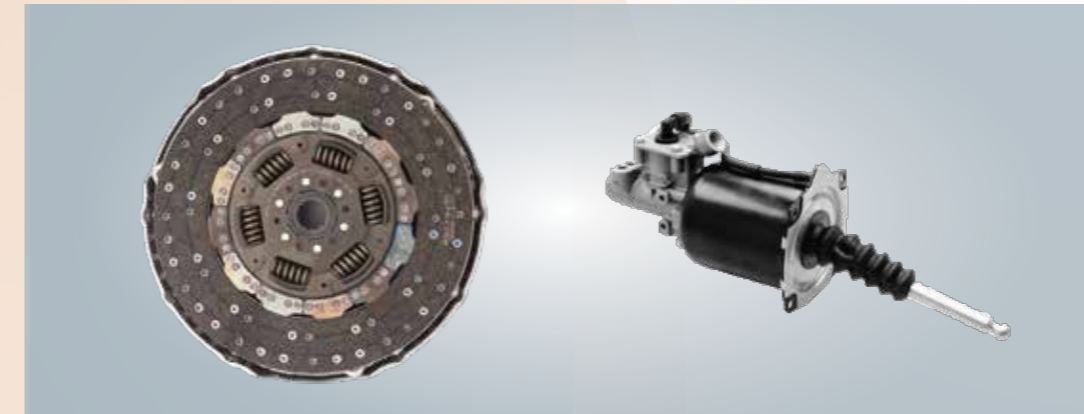

Bigger Clutch with Clutch Booster for Fatigue-free Driving



4-way Adjustable and Fully Reclining Driver's Seat with well-ventilated Driver Cabin



Tilt and Telescopic Steering

## ITS SAFETY IS DESIGNED AROUND YOUR SAFETY.



Projector Lamps for Better Brightness and Night Vision

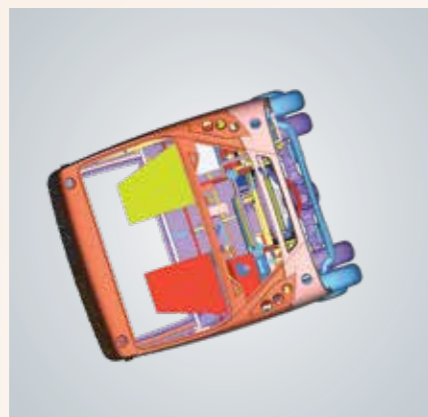

Rollover Compliant for Maximum Safety for Passengers



Biggest Brake Liners for Reduced Stopping Distance



Anti-Roll Bar at front & Rear for Better Stability



Tubular Structure for More Durability

## GET THE DELIGHT OF UNMATCHED CONVENIENCE.



Dual Ports USB Charger for each Passenger



Driver-friendly Information System - Displays Average Mileage, Current Gear, Trip km and Air Pressure. Malfunction Indicators Help Prevent Breakdowns.



Downward Open-able Front Flap for Easy Checks, Tools-access and Servicing



Luggage Space for Extra Convenience



Speaker Mounting Provisions to Make Journeys Entertaining

## CRUZIO GRANDE BS6 SPECIFICATIONS

CRUZIO GRANDE 4440 BS6

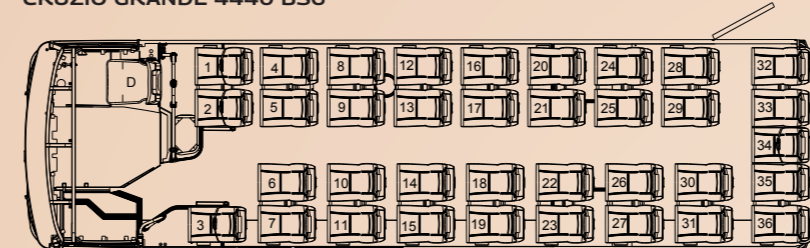

CRUZIO GRANDE 5360 BS6

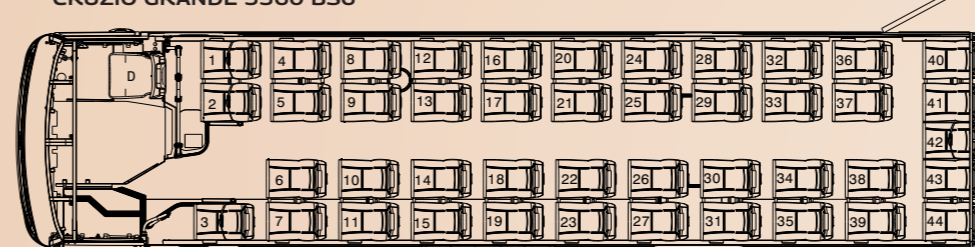

## CRUZIO GRANDE RTD also available

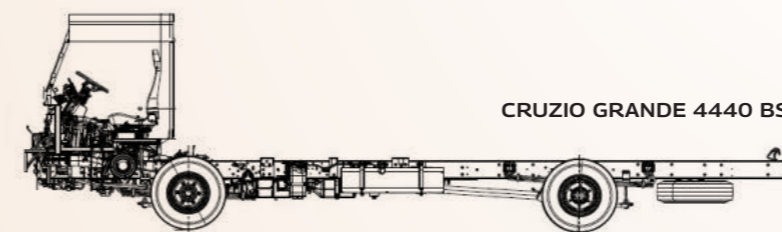

CRUZIO GRANDE 4440 BS6

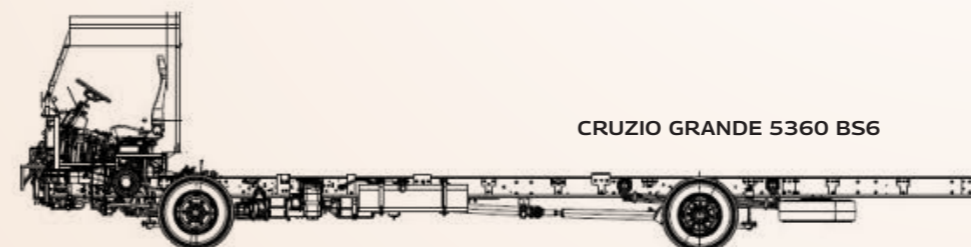

CRUZIO GRANDE 5360 BS6

Model	CRUZIO GRANDE 4440 BS6	CRUZIO GRANDE 5360 BS6
Engine	3.5 litre mDi Tech Fuel Efficient Engine	
Max. Power	103 kW @ 2400 r/min	
Max. Torque	525 Nm @ 1250-1800 r/min	
Gear Box	6 Speed Synchromesh Gear Box with overdrive	
Suspension	Parabolic Leaf Spring with Anti Roll bar (Front & Rear)	
Clutch	362 mm Diameter with Clutch booster	
Tyres	235/75 R17.5 14PR Tubeless	
Steering	Power Steering	
Brake System	Air Brakes with ABS	
Fuel Tank	120 litre	
Battery	12 V - 120 Ah	
Passenger Door	1 Jack-Knife type	
Floor	Anti Skid Vinyl Flooring	
TCD	15400 MM	17600 MM
Seating Capacity	36+D HHR	44+D HHR
Wheelbase	4440 mm	5360 mm
Overall Length	8950 mm	10415 mm
Overall Width	2350 mm	2350 mm
Overall Height	3020 mm	3020 mm
GVW	9200 kg	10100 kg

# MONITOR YOUR BUS EVERY SINGLE MOMENT.

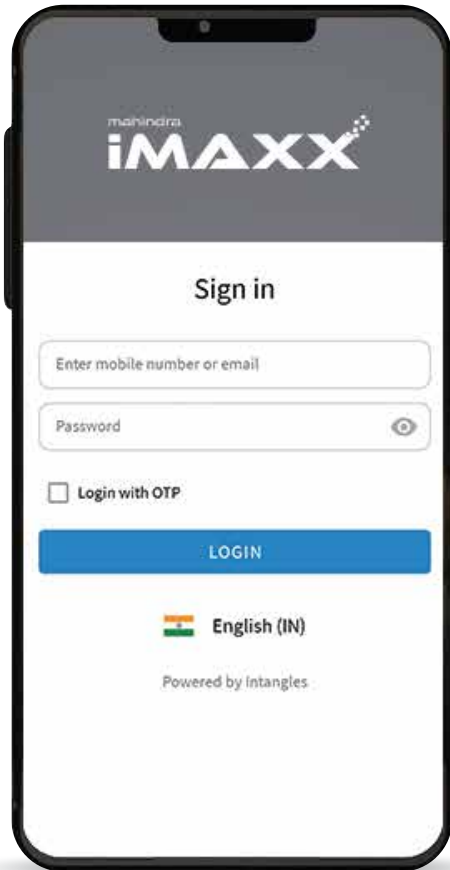

## VEHICLE HEALTH MONITORING



Fault Codes (DTC) and Repair Strategies



Battery and Alternator



Engine Temperature Check



Turbocharger and Intercooler

## DRIVING BEHAVIOUR MONITORING



Neutral Driving and Gear Utilisation



Idling



Hard Braking and Harsh Acceleration



Over Speeding

## FUEL AND ADBLUE ANALYSIS



Fuel Economy Analysis



Fuel Filling and Theft Monitoring



AdBlue AUS32 Monitoring



FuelSmart Switches Usage Analysis

## OPERATIONS AUTOMATION



Hub Reports



Vehicle Utilisation Reports



Vehicle Live Data



Location Track and Trace



Get Timely Service Reminders



**MAHINDRA AASHRAY**  
MAHINDRA AASHRAY MAKES EVERY MOMENT CAREFREE.



**MRECON**  
Uncompromising performance. Assured profitability.



**MTRUST**  
Pre-owned Commercial Vehicles

Mahindra brings you MTRUST, the best way to buy used Mahindra trucks. We put each vehicle through 166 tough health checks. Refurbish with only Mahindra spares. All to give you trucks that are as good as new and outperform right from the start.

• UP TO 12 MONTHS WARRANTY • 1/2/3 STAR RATINGS • UP TO 3 FREE SERVICES • ROADSIDE ASSISTANCE • REFINANCE OPTIONS



Corporate: [contactmtb@mahindra.com](mailto:contactmtb@mahindra.com)  
Customer Care: [now24X7@mahindra.com](mailto:now24X7@mahindra.com)



[www.mahindratruckandbus.com](http://www.mahindratruckandbus.com)



### Mahindra and Mahindra Ltd.

Truck and Bus Division, Marketing Division, Mahindra Tower, 3<sup>rd</sup> Floor, Wing 3, Chakan Industrial Area, Phase IV, Post - Nighoje.Chakan, Tal Khed, District Pune - 410 501

Note: In view of our policy of continuously improving our products, we reserve the right to alter specifications or design without prior notice and without liability. Illustrations do not necessarily show the vehicle in its standard form. Accessories shown are not part of the standard equipment. Colour shades shown may vary. E. & O.E.

DEALER STAMP

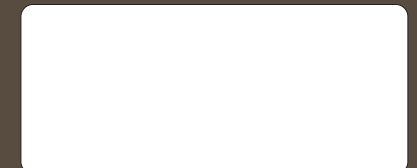

To know more, give us a missed call on:  
**1800 315 7799**  
Visit [www.mahindratruckandbus.com](http://www.mahindratruckandbus.com)

 **MOBILE SERVICE VANS & WORKSHOPS**

 **COUNTRY-WIDE SPARES & SERVICE NETWORK**

 **WHATSAPP US ON:  
8484970171**

 **1800-200-3600**  
24/7 VEHICLE ASSISTANCE BY EXPERTS  
A MULTILINGUAL SERVICE